

# WHO WE ARE WHAT WE DO



## FEDERAL SOLUTION TO PROTECT LIVES

### ▶ WHO WE ARE

Shellter™ was established by a collective of esteemed professionals from the Federal Law Enforcement, Special Operations, Intelligence Community, and security industry. We share a common concern over the escalating incidents of active shooter/mass shooter events. Shellter™ alleviates Employee Fear and mitigates Property Manager and Company Liability with our UL rated ballistic Shellter Shield Walls, and a Shellter door barricade. We provide a Shellter™ for employees to seek refuge during an active shooter situation.



**“Active Shooters in the office space are on the rise...”**

### ▶ WHAT WE DO

Our installations increase property value, increase employee satisfaction, divest the management of liability, and pivot companies into the future. Active Shooters in the office space are on the rise and the employee fear index in this regard is skyrocketing. Employees want to know measures are being taken to make them secure. Property managers and company owners have a duty of care to their employees. Our product creates an environment safer from active shooters and is a vital addition to every office space which is becoming the new normal.

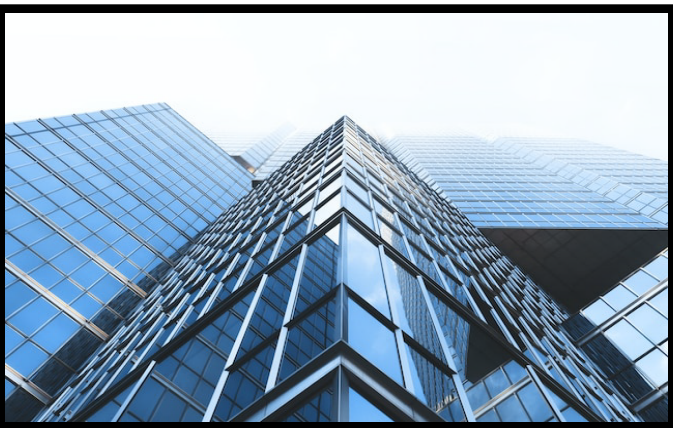

**“...and the employee fear index in this regard is skyrocketing.”**



[www.shellterus.com](http://www.shellterus.com)

# THE PROBLEM



## ► NATIONAL STATISTICS

As Americans, we have been heartbroken by the loss of life as a result of mass shootings. We've been told by Department of Homeland Security, to "hide," yet no one has come up with a solution as to where and how to hide.

- **Total number of mass shootings in 2022: 648**
- **The % of shootings that occur in businesses: 51%**
- **Average wait until police arrive: 11 minutes**
- **Since 2014, shootings are up over 200%**

**Your employees need protection. Protect them with Shellter™**

## RESPONSIBILITY OF THE BUILDING OWNER

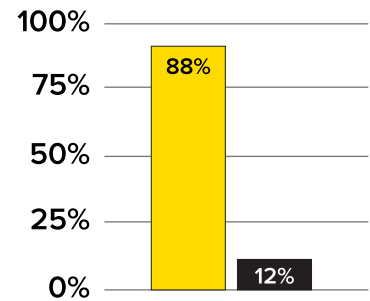

**Overall Total**

Almost 9 out of 10 (88%) respondents said it is the building owner's duty to provide a protective solution to an active shooter situation. (Businesses with 50+ employees)

## SAFETY/NEGLIGENCE

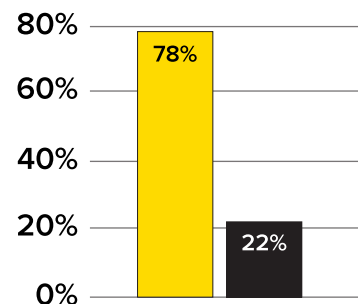

**Overall Total**

3 out of 4 (78%) respondents said that it is negligent to not offer a protective solution. (Businesses with 50+ employees)



# Your employees need protection. Protect them with SHELLTER™

“Shellter™ transforms an ordinary room into a secure refuge for occupants during an active shooter situation...”

## ▶ THE SYSTEM

### 1. THE SHELLTER™ SHIELD WALL

The Shellter™ Shield Wall is a UL rated physical bullet resistant fiberglass panel located between the shooter and the people behind it, providing ballistic protection to the Shellter™ room.

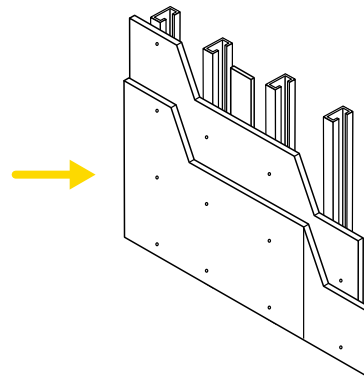

- ▶ THE Shellter™ BALLISTIC SHIELD IS TWO UL RATED BALLISTIC SHIELDS.
- ▶ MOUNTED DIRECTLY TO METAL OR WOOD STUDS.
- ▶ OVERLAPPED TO ENSURE RATED BALLISTIC PROTECTION

### 2. THE SHELLTER™ BARRICADE

The Shellter™ Barricade provides a secure UL approved physical entry deterrent to the Shellter™ room, securing those inside.

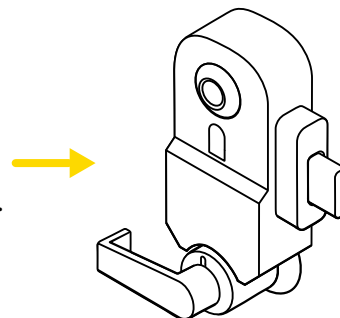

- ▶ Shellter™ BARRICADE IS ACTIVATED WITH A ONE-TOUCH BUTTON.
- ▶ MEETS DEPARTMENT OF HOMELAND SECURITY'S #1 RECOMMENDATION.



[www.shellterus.com](http://www.shellterus.com)

## ▶ PROPRIETARY SAFETY PACK

### 3. SHELLTER™ 911 RESCUE

Shellter™ 911 Rescue is an emergency response call out that provides a one-touch call in the event of a life-threatening situation. The 911 callout system allows individuals to quickly and easily make a direct call to emergency services, providing critical information and alerting first responders to the nature and location of the emergency.

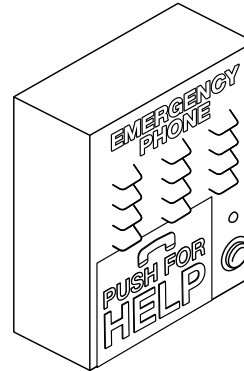

- ▶ EMERGENCY RESPONSE MECHANISM DESIGNED TO PROVIDE IMMEDIATE ASSISTANCE
- ▶ SYSTEM ALLOWS INDIVIDUALS TO QUICKLY AND EASILY MAKE A DIRECT CALL TO EMERGENCY SERVICES

### 4. SHELLTER™ TRAUMA KIT

Shellter™ Trauma Kit provides essential equipment that empowers the general public to take action to stop life threatening bleeding and provide basic wound care (tourniquet, blood clotting kit, sterile dressings, gauze, etc.)

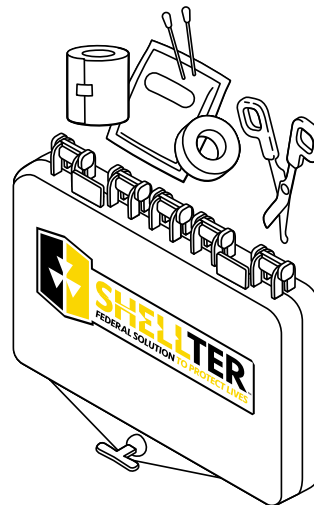

- ▶ NECESSARY ITEMS TO TREAT IMMEDIATE LIFE THREATENING INJURIES.
- ▶ MEDICAL SUPPLIES NECESSARY FOR BASIC WOUND CARE AND FIRST AID.
- ▶ INCLUDES ITEMS SUCH AS STERILE DRESSINGS, GAUZE, ADHESIVE BANDAGES, TOURNIQUETS, SCISSORS, AND GLOVES.



[www.shellterus.com](http://www.shellterus.com)